

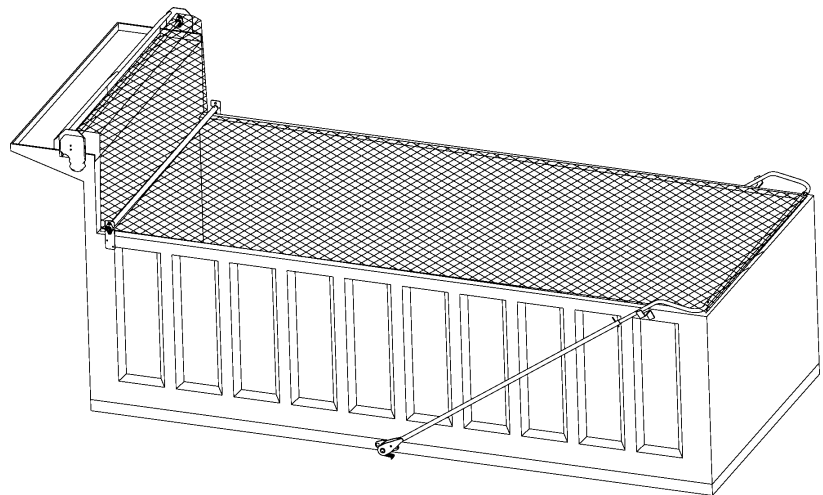

TARP TRAP

#4096

INSTALLATION INSTRUCTIONS



SEPTEMBER 2010

Donovan Enterprises, 3353 SE Gran Park Way, Stuart FL 34997
800-327-8287

www.donovan-ent.com

TARP TRAP INSTALLATION INSTRUCTIONS

BEFORE INSTALLATION BEGINS

- READ AND UNDERSTAND INSTALLATION INSTRUCTIONS.
- UNPACK SYSTEM AND CHECK ALL PARTS AGAINST PACKING LIST.

TARP TRAP COMPONENTS

ITEM	PART #	DESCRIPTION	QTY
1	4419	BEARING PLATE	2
2	121	ROLLER BAR, 1" DIA.	1
3	3278	ROLLER BAR EXTENSION, 3/4" x 6"	1
4	148	SHAFT COLLAR, 3/4"	2
	2464	3/8" x 1 1/2" HEX HEAD BOLT	4
	2687	3/8" NUT, LOCK	4
	2688	WASHER, FLAT 3/8" USS	4

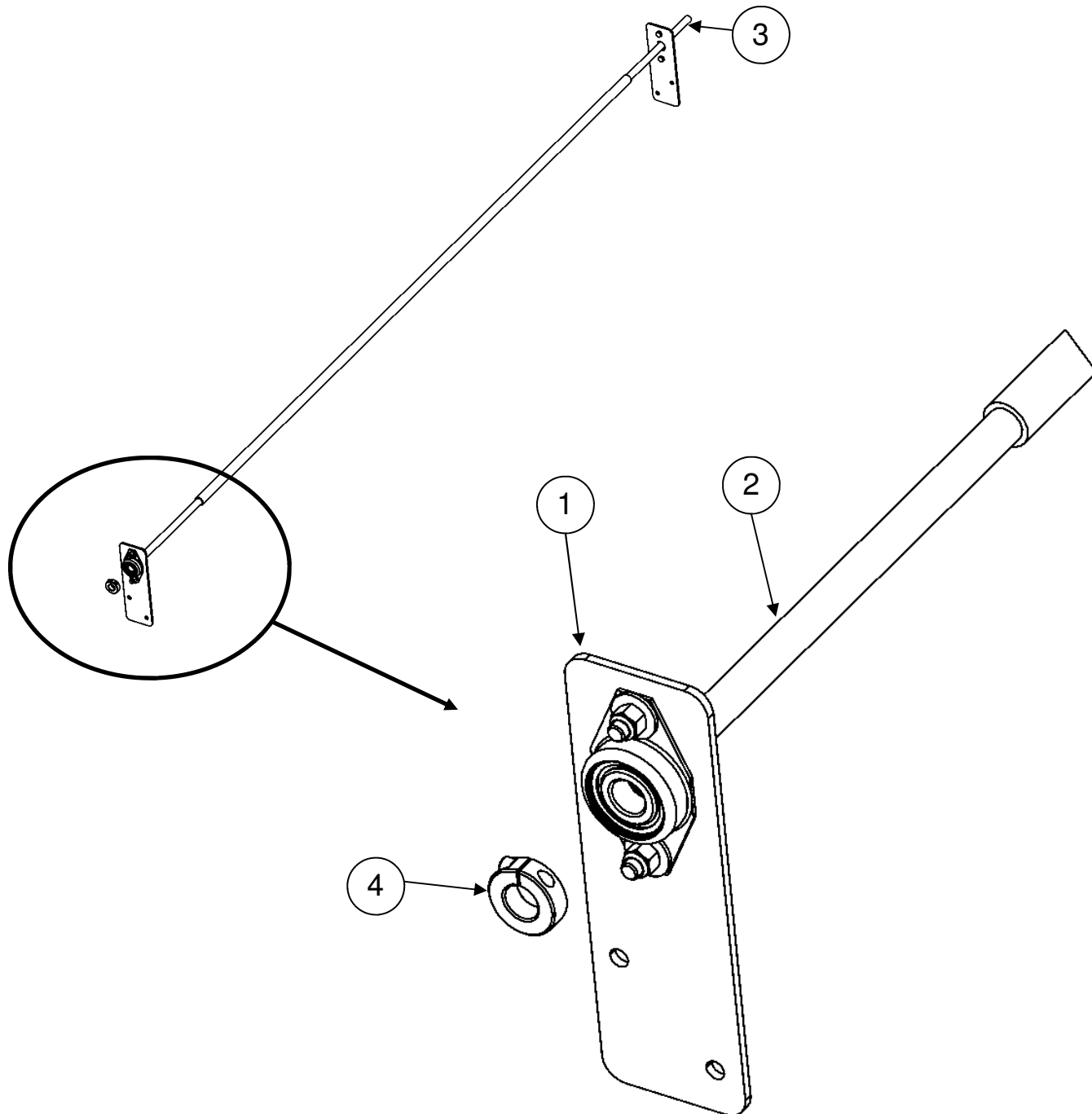

TARP TRAP INSTALLATION INSTRUCTIONS

Mounting the Bearing Plate Assemblies

1. In general, the Tarp Trap will be mounted as closely to the bulkhead as possible. This will prevent material from blowing and damaging the tarp.
2. After the location is decided, mount bearing plate using included carriage bolts, or weld into position. Make sure that the driver's side and passenger side are located in the same position, respectively.

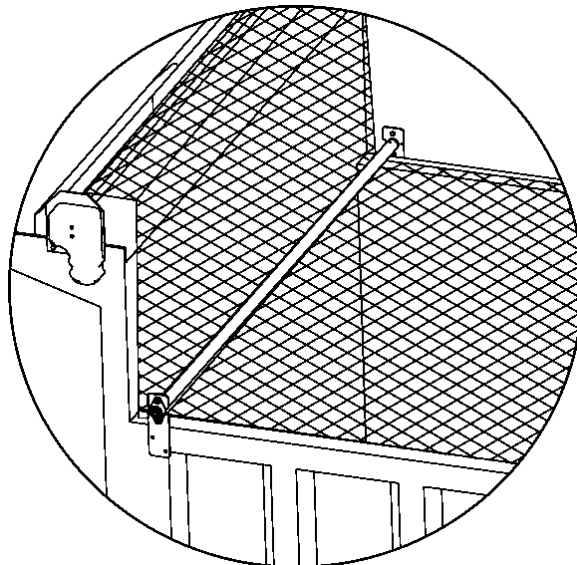
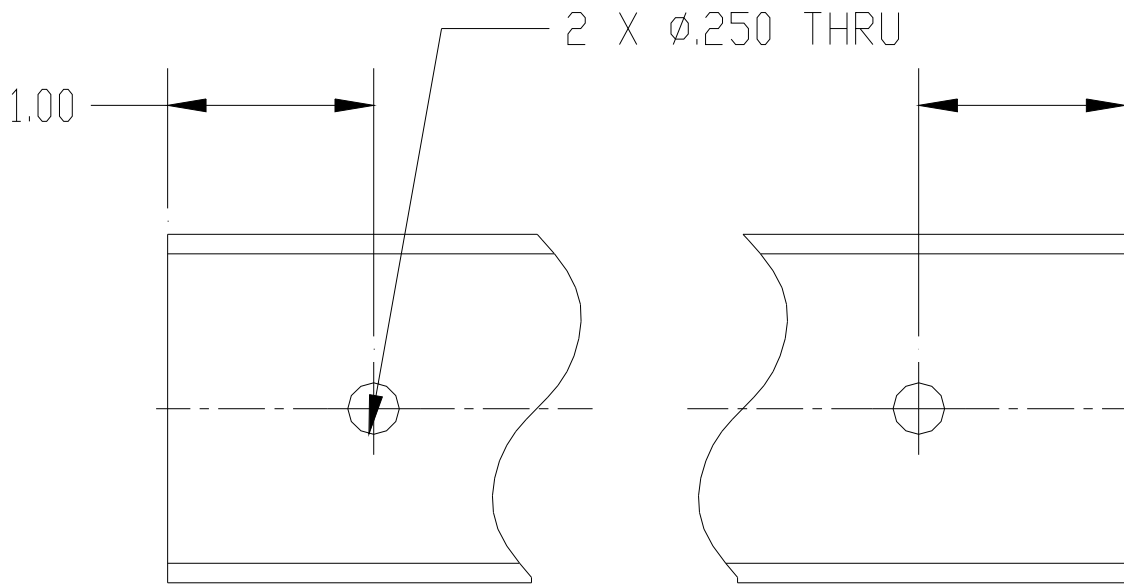

Final Assembly (continued)

3. Insert the 3/4" shaft end of the Roller Bar into one of the 3/4" Bearings. The 6" Shaft can now be slid through the other Bearing into the hollow end of the Roller Bar.
4. Place assembly into position. (If the Roller Bar is too long, it must be trimmed.)
5. Weld 6" shaft into Roller Bar
6. Center Roller Bar assembly on truck.
7. Place Shaft Collars on both sides of the Roller Bar assembly and tighten set screws located in the Shaft Collar.

