

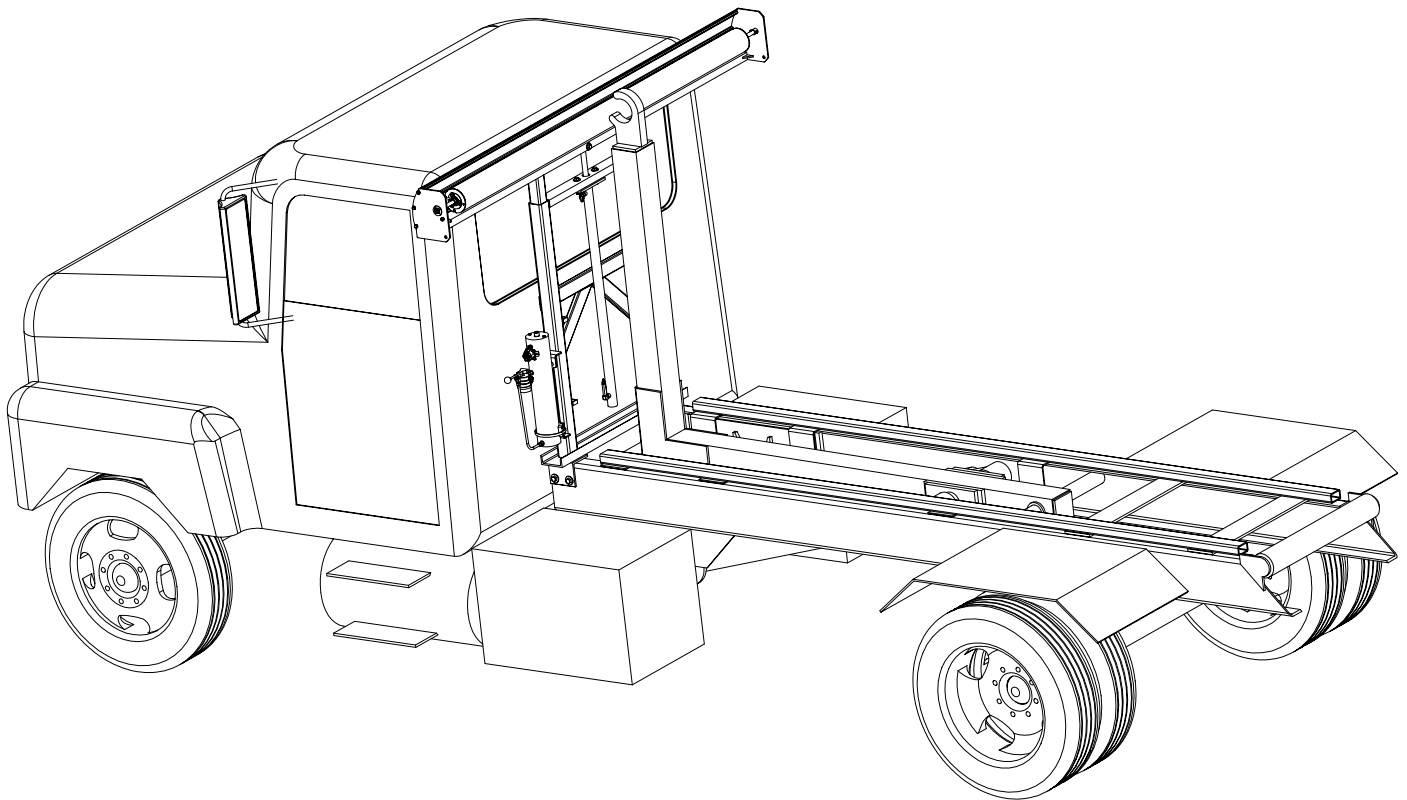

HY-TOWER SAHL

Two stage Hy-Tower for single axle hook-lifts (part# 2423)



OWNER'S MANUAL

05/05/07

Donovan Enterprises, 3353 SE Gran Park Way, Stuart FL 34997

800-327-8287

www.donovan-ent.com

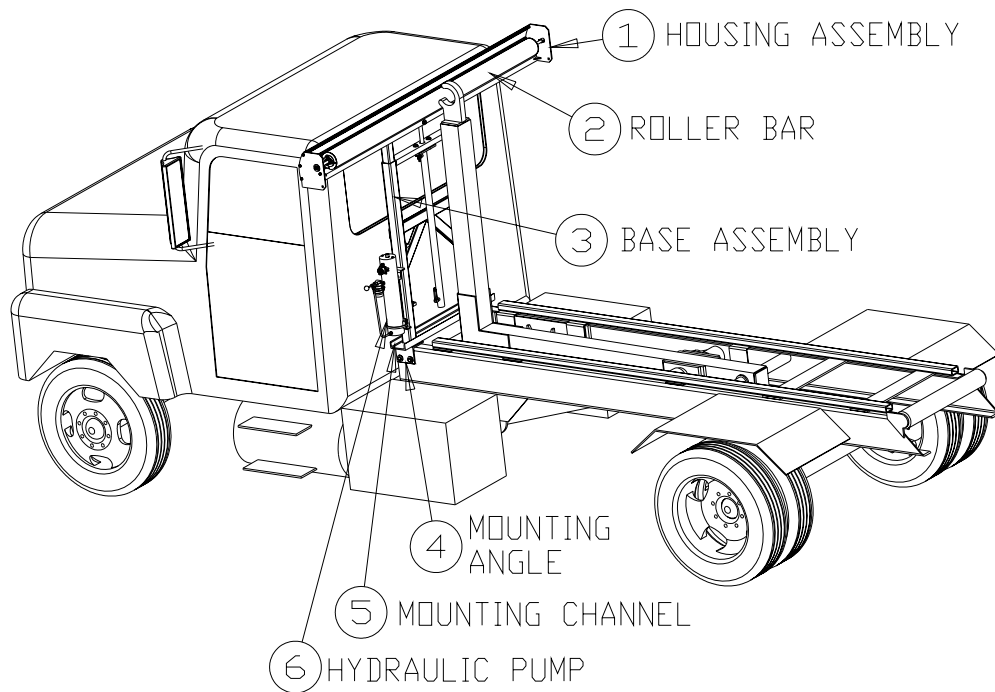

PART #	QTY	BALLOON	DESCRIPTION
2423	1	N/A	HY-TOWER FOR SINGLE AXLE HOOK LIFTS
1638	1	1	HOUSING ASSEMBLY WITH TARP, BOXED
4345	1	3	BASE ASSEMBLY
2348	1	5	MOUNTING CHANNEL
2347-5	2	4	MOUNTING ANGLE
4353	1	6	12 VOLT HYDRAULIC PUMP KIT
<u>HOUSING HARDWARE</u>			
2878	6	N/A	1/2" FLAT WASHERS
2877	5	N/A	1/2" - 13 LOCK NUT
2348	1	N/A	1/2" - 13 X 4" HEX HEAD BOLT
<u>HOUSING ASSEMBLY BREAKDOWN (part# 1638)</u>			
2978	1	N/A	TARP
4023	1	N/A	COMPOSITE PULL BAR ASSEMBLY
3876	1	N/A	3/8" X 50' ROPE ASSEMBLY WITH STEEL RING
3877	1	N/A	5/16" X 8' ROPE ASSEMBLY WITH SNAP CLIPS
3268	1	2	ROLLER BAR WITH SPRING
1637	1	1	HOUSING ASSEMBLY WITHOUT TARP
<u>BASE ASSEMBLY BREAKDOWN (part# 4345)</u>			
4342	1	N/A	OUTER STAGE
4344	1	N/A	INNER STAGE
420	1	N/A	HYDRAULIC CYLINDER
<u>12 VOLT HYDRAULIC PUMP ASSEMBLY BREAKDOWN (part# 4353)</u>			
1570	1	N/A	150 AMP CIRCUIT BREAKER
4350	1	N/A	STEEL PUMP MOUNTING BRACKET
4354	2	N/A	84" HYDRAULIC HOSE
452	1	6	HYDRAULIC PUMP
835	1	N/A	4 GA WIRE, 16' LONG

HY-TOWER HL INSTALLATION CLEARANCE REQUIREMENTS

- A minimum clearance of 12" between the cab and hook-lift (see figure 3-1) is required. If the exhaust system or parts of the hydraulic system are located between the tilt frame and the cab, then you will need a minimum of 12" between these components and the tilt frame. It may be necessary to relocate some components to achieve a 12" clearance.

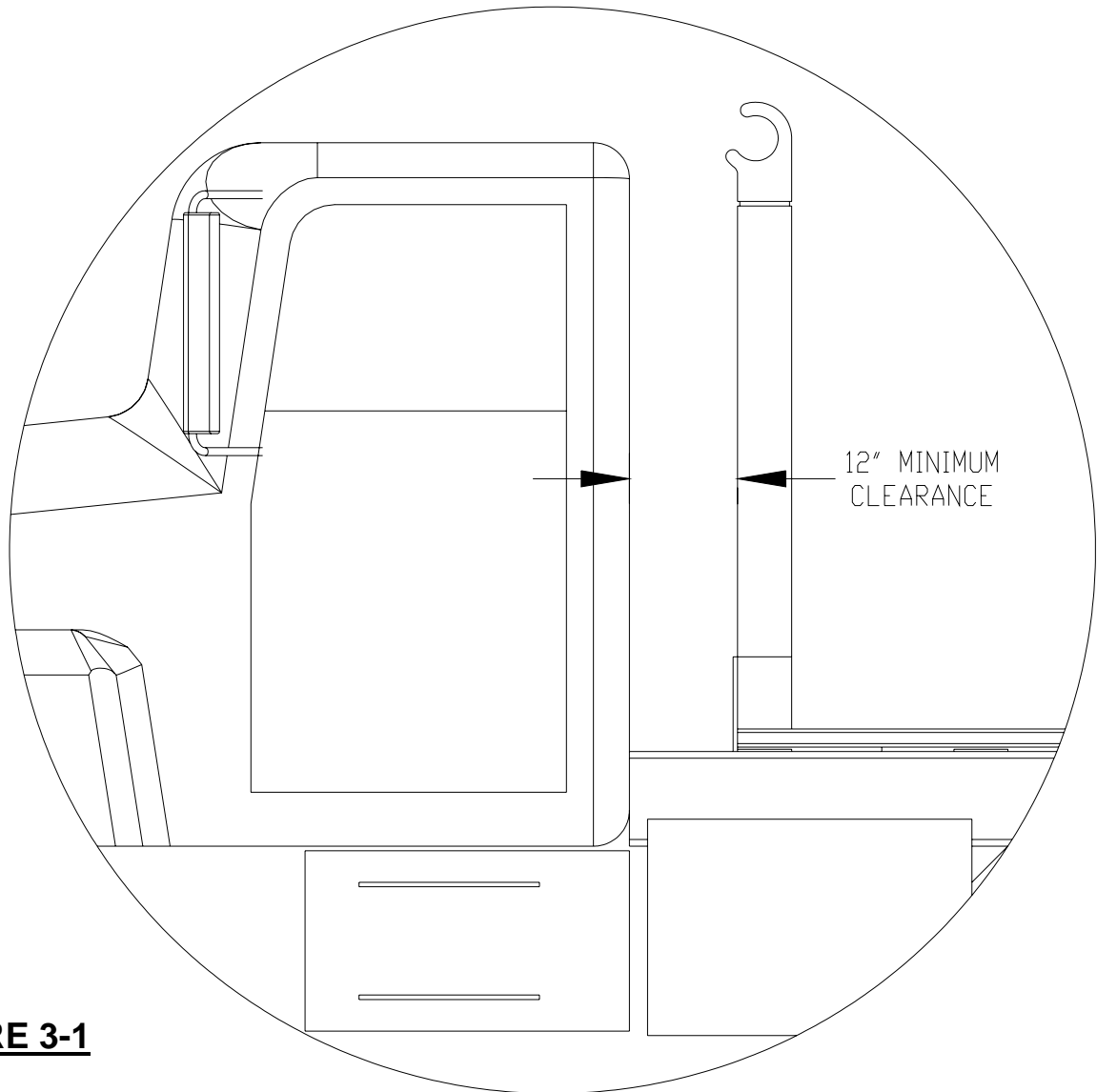

FIGURE 3-1

Exhaust system and other components may interfere with the standard mounting brackets supplied by Donovan Enterprises. Occasionally, special brackets may need to be fabricated by the installer to clear this interference if it is not practical to move these components.

HY-TOWER HL INSTALLATION INSTRUCTIONS

Installing Base Assembly

CAUTION: Welding to frame may weaken frame and void trucks warranty. However, if there are brackets already installed on truck frame then you can weld angle brackets to those brackets instead of drilling holes in frame and bolting brackets in place.

- Mount angle brackets to the driver and passenger side truck frame. Locate the brackets as close to the cab as possible in the space between cab and hook-lift. Attach angle brackets by bolting with 5/8" bolts, washers, and lock nuts (not supplied) or welding in place. Position mounting channel centered from side to side and front to rear on mounting angles (see figure 4-1).

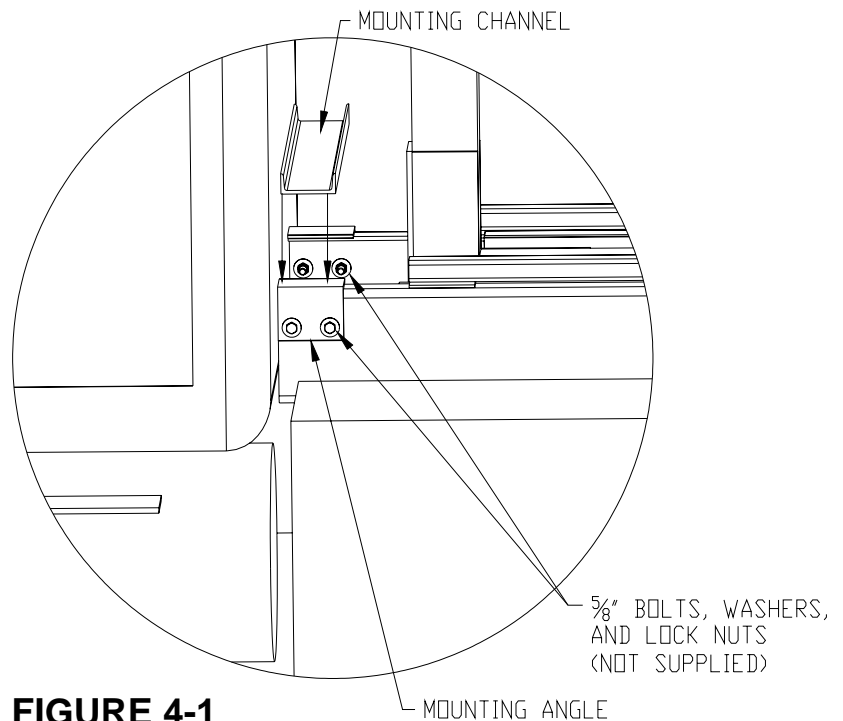

FIGURE 4-1

CAUTION: Base assembly must be centered on mounting channel with a minimum of 12" clearance. If base assembly is not centered with at least 12" of clearance the Quick Flip system could be damaged and/or will not operate properly.

- Square and center base assembly on mounting channel in clearance area. Weld both legs to mounting channel that you just installed on truck. It may be necessary to make and weld additional bracing to base assembly legs and channel to provide stability of system (see figure 4-2).

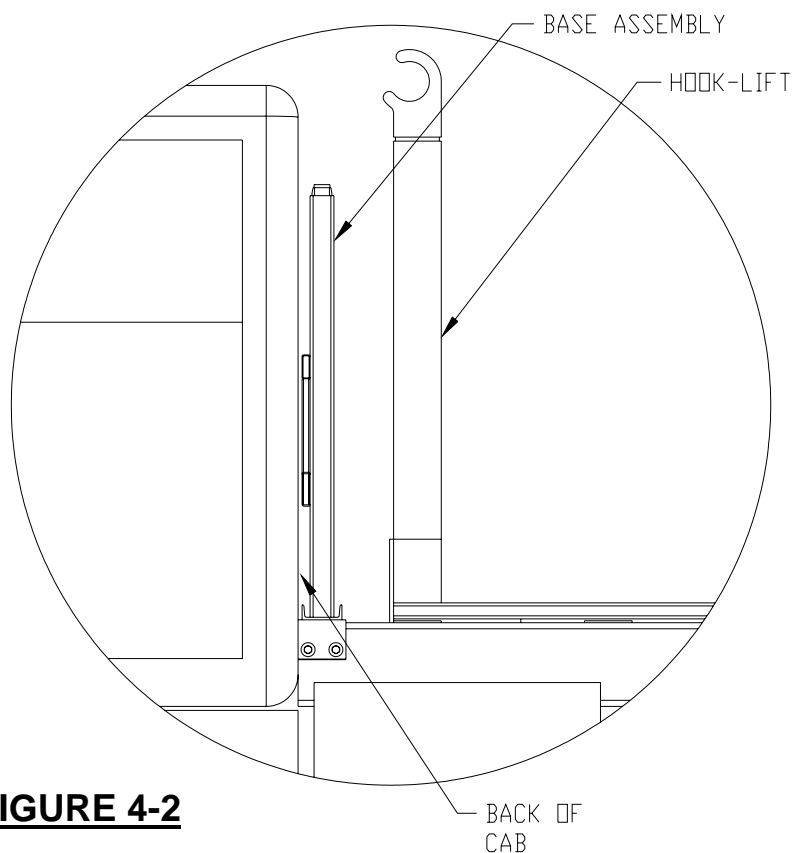
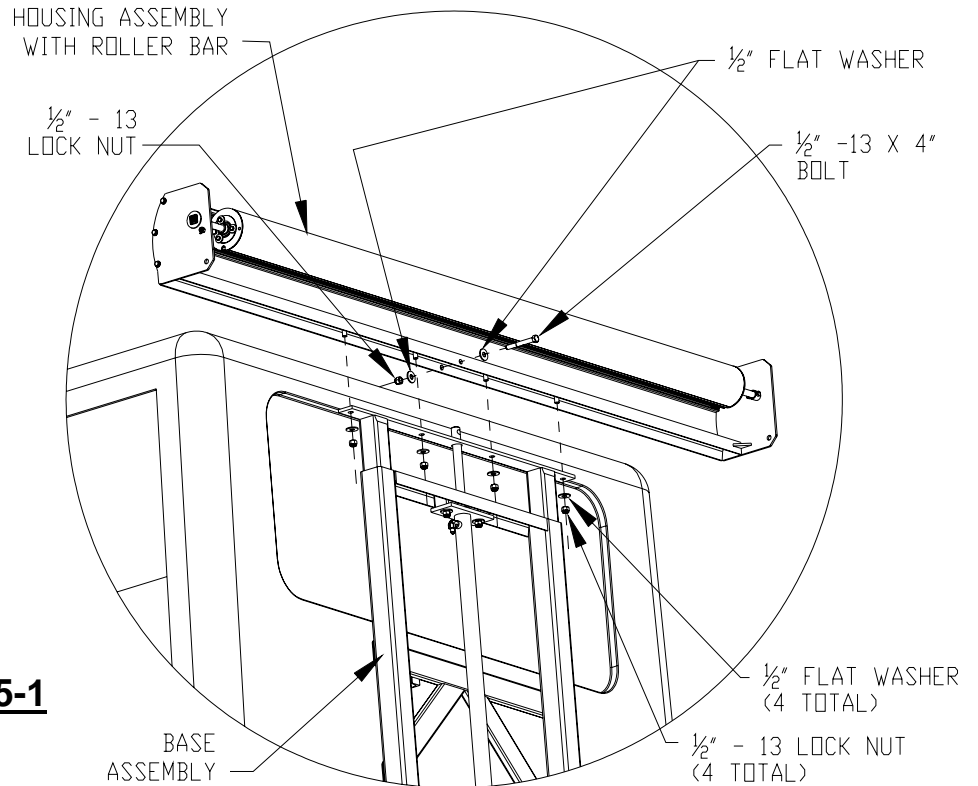

FIGURE 4-2

Installing Housing Assembly

- Mount housing assembly to the base assembly using the four studs welded to the housing assembly, $\frac{1}{2}$ " flat washers, and $\frac{1}{2}$ " lock nuts (see figure 5-1).
- Attach the hydraulic cylinder rod to the roller bar housing assembly with one $\frac{1}{2}$ " - 13 x 4" grade 8 bolt, two $\frac{1}{2}$ " washers, and one $\frac{1}{2}$ " lock nut (see figure 5-1).

FIGURE 5-1



Installing Hydraulic Pump

- The hydraulic pump must be mounted vertically with the control valve and motor on the top and the reservoir on the bottom.
- Weld the pump mounting bracket to the outer leg or in a location easily accessible by the driver (see figure 5-2).
- Attach the two hydraulic hoses installed on pump to the hydraulic cylinder.

FIGURE 5-2

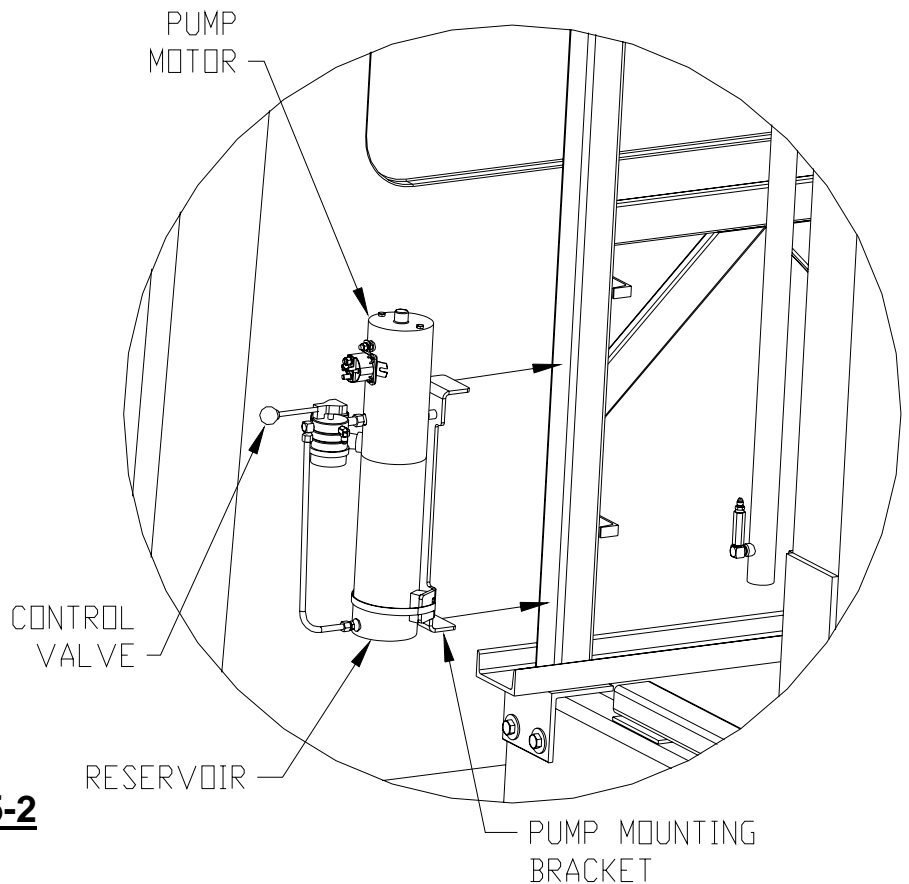

Hydraulic Pump Preparation

- Ensure the hose clamp is tight around the reservoir for proper support.
- Remove the shipping plug from the fill port and fill pump with approximately 4 quarts of dexron automatic transmission fluid.

CAUTION: If you do not replace the shipping plug with a breather cap on the hydraulic pump you will cause damage to the pump.

- Install the supplied breather cap onto the fill port. **Do not reinstall the shipping plug.**
- Connect the negative lead from the battery to the pump mount stud.
- Connect the positive lead from the battery, to the lower 5/16" stud on the front of the solenoid.
- Place the solenoid cover (not shown) over the solenoid. Attach cover to pump with the supplied 8" zip tie.

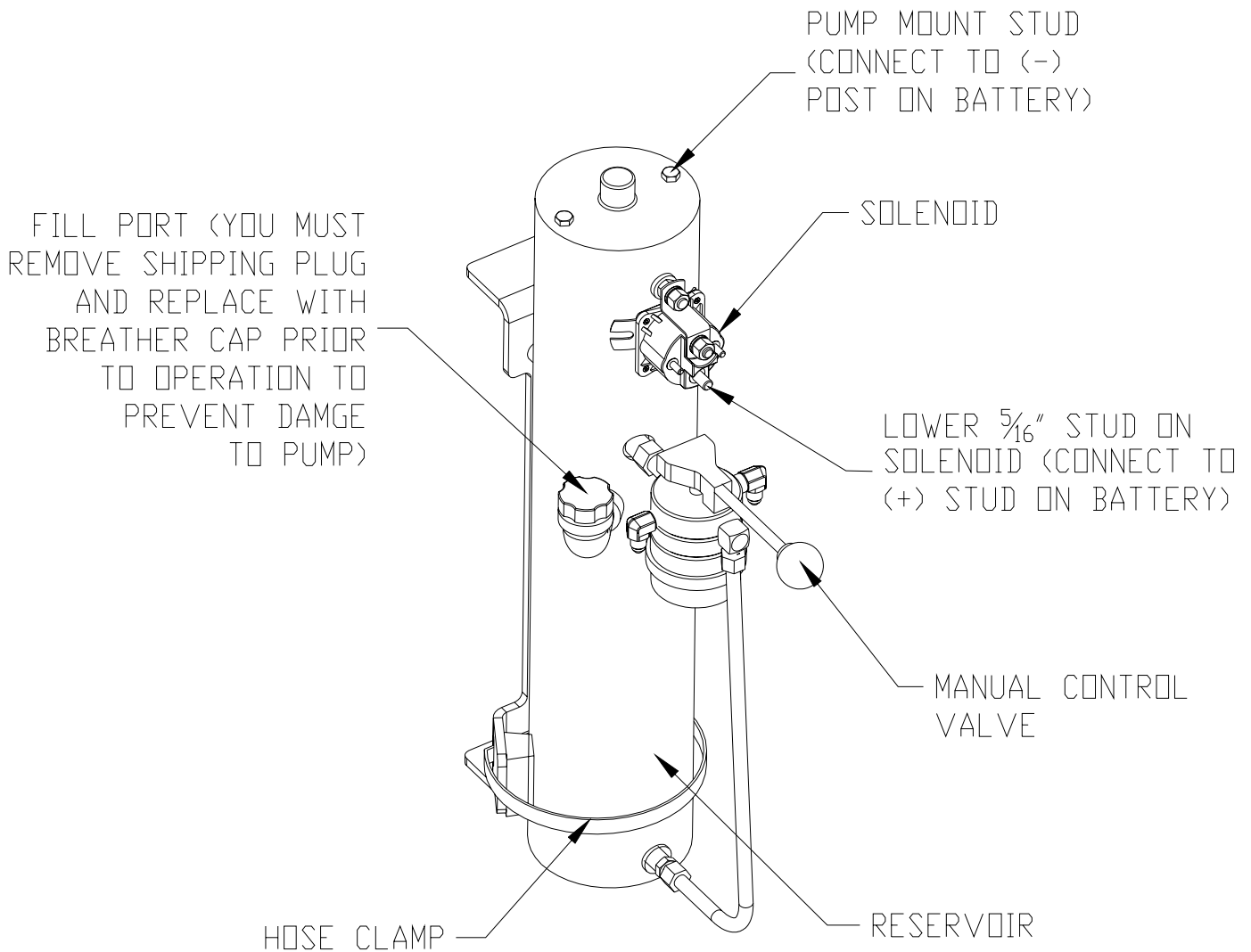

HY-TOWER WARNING FLASHER INSTALLATION

- After the Hy-Tower unit has been installed, the warning flasher and cutout switch needs to be installed.
- Determine mounting location of warning flasher bracket inside cab of truck. Warning flasher must be easily visible to driver.
- Run wires (three wires inside jacket) that are bundled at end of conduit near base of Hy-Tower to the warning flasher you just mounted in truck.
- Connect black wire from alarm switch to the quick disconnect on wire attached to light.
- Connect blue and red wires from alarm to quick disconnect tabs on back of toggle switch (it does not matter which wire goes to what tab)
- Connect black wire coming from light (this wire does not have quick disconnect) to a 12 volt DC power source.

TEST OPERATION

- Place toggle switch in on position and raise the stage at least 1" and listen for alarm and watch light coming on. Then lower system and sure light and alarm go off.
- Place toggle switch in off position and try to operate system. Hydraulic pump should not start.
- If these tests do not pass, then verify all wires are connected properly per these instructions and try again. If still having problems call Donovan Enterprises to technical support.

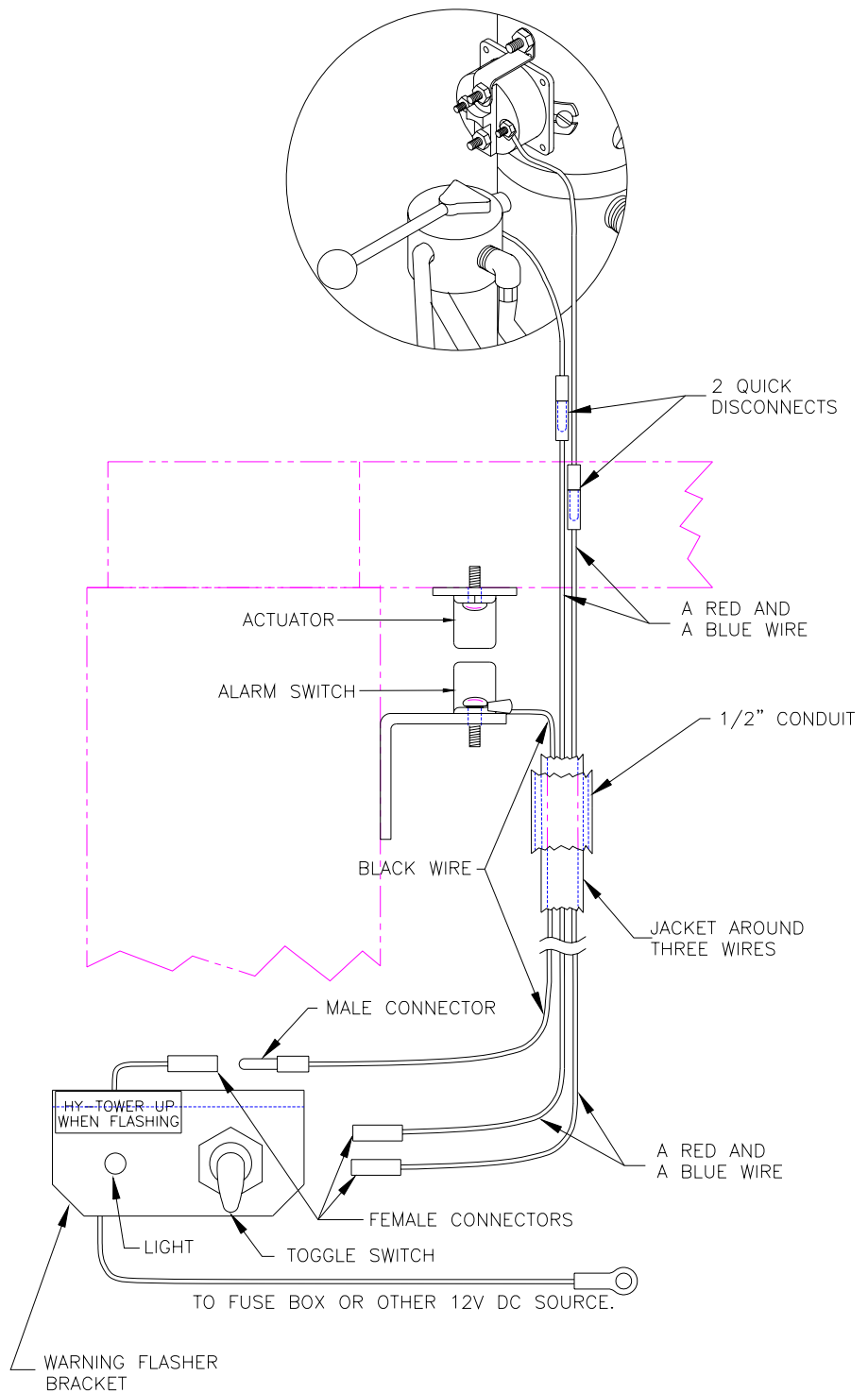

TARP INSTALLATION

- Slide spline in tarp into groove in roller bar. Tarp should be centered on roller bar.
- Slide the two 3' long foam insulation sections onto each end of the composite pull-bar. Use one zip tie around foam and pull-bar to hold each foam piece in place.
- Slide pull bar into tarp pocket on opposite end that is attached to roller bar.
- Close the end of the tarp pocket using 3 zip ties on each end (6 total).

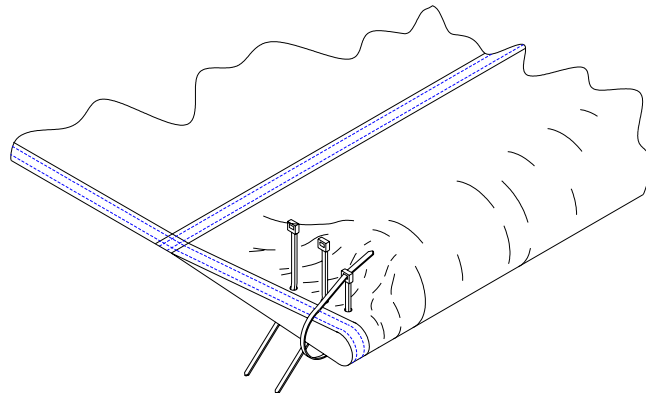
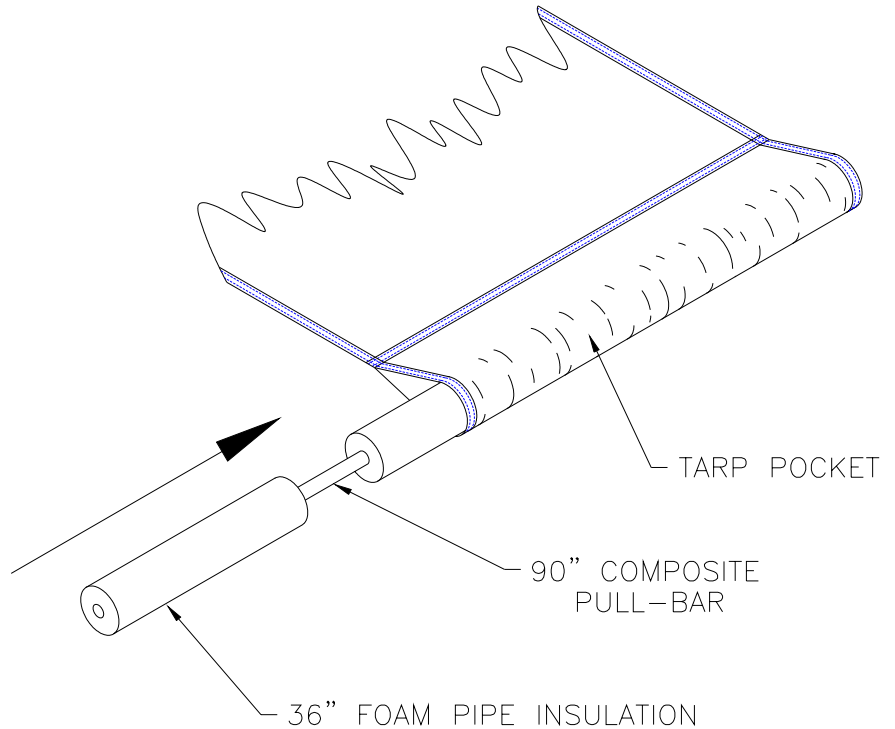

ROLLER BAR PRE-LOAD TENSION WARNING

- Do not adjust roller bar spring tension without proper sized 1" (2.5 CM) wrench.
- Maintain a tight grip on wrench at all times to avoid possible injury.
- Always ensure lock paw is fully engaged in ratchet before releasing wrench.
- Recommended pre-load turns of roller bar:
 - Lightweight tarp: 32 turns
 - Heavyweight tarp: 38 turns
- Do not exceed 50 turns total (do not forget to add pre-load turns to the number of turns that you have added) or you may cause spring to break.

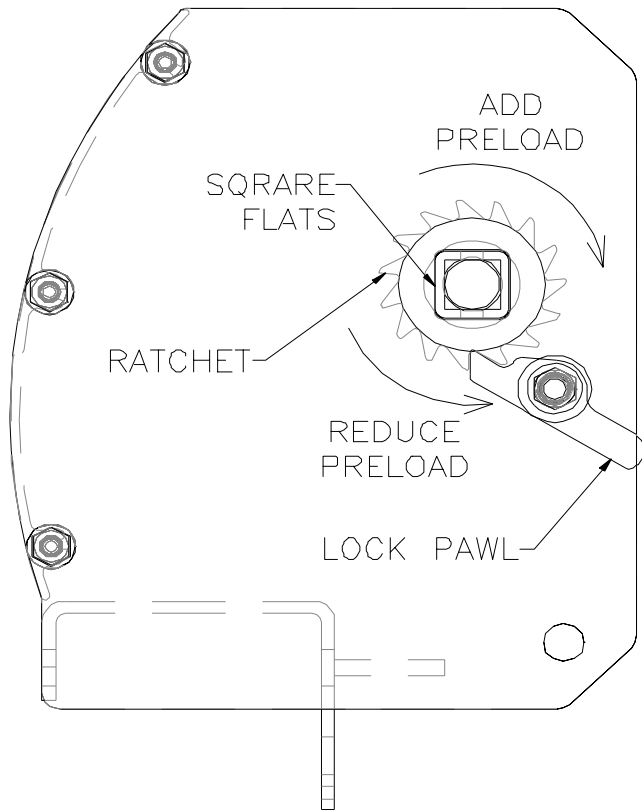

SPRING TENSION ADJUSTMENT

INCREASE SPRING TENSION:

CAUTION: Lock pawl must be fully engaged before wrench is removed to prevent personal injury.

- Use a 1" (2.5 CM) wrench on square flats and rotate ratchet clockwise while counting each full rotation.

DECREASE SPRING TENSION:

CAUTION: Lock pawl must be fully engaged before wrench is removed to prevent personal injury.

- While holding a 1" (2.5 CM) wrench on square flats, lift lock pawl to disengage pawl. Rotate ratchet counterclockwise until desired tension is achieved.

TARP INSTALLATION (continued)

- Add pre-load to roller bar. After the first few turns the tarp should start rolling up on the roller bar. Ensure the tarp does not get caught on the truck and rolls up straight on roller bar.

CAUTION: DO NOT EXCEED A TOTAL OF 50 TURNS ON THE ROLLER BAR.

- Once the tarp has fully rolled up on the roller bar add three to five more turns of preload.
- With system raised pull tarp out and then let roller bar roll tarp back up. Adjust pre-load as necessary to have the least amount of tension necessary to fully roll tarp on roller bar.



Thank You for Your Purchase

www.donovan-ent.com

Donovan Enterprises • 3353 SE Gran Park Way • Stuart, Florida 34997 1-800-327-8287